



ADVISORY CIRCULAR AC 139.F-01 v1.0

Design and operation of Australian water aerodromes

Date June 2020
File ref D20/155456

RESTRICTED DRAFT / UNCONTROLLED WHEN PRINTED

Advisory Circulars are intended to provide advice and guidance to illustrate a means, but not necessarily the only means, of complying with the Regulations, or to explain certain regulatory requirements by providing informative, interpretative and explanatory material.

Advisory Circulars should always be read in conjunction with the relevant regulations.

Audience

This advisory circular (AC) applies to:

- persons involved in the design, construction and operation of water aerodromes
- proponents of water aerodromes
- planning authorities
- aerodrome and aircraft landing area operators
- the Civil Aviation Safety Authority (CASA).

Purpose

The purpose of this AC is to provide guidance and advice about CASA's requirements for the design and operation of water aerodromes.

For further information

For further information, contact CASA's Air Navigation, Airspace and Aerodromes Branch (telephone 131 757 or email aerodromes@casa.gov.au).

Status

This version of the AC is approved by the Manager, Flight Standards Branch.

Version	Date	Details
v1.0	June 2020	Initial AC.

Unless specified otherwise, all subregulations, regulations, divisions, subparts and parts referenced in this AC are references to the *Civil Aviation Safety Regulations 1998 (CASR)*.

Contents

1	Reference material	3
1.1	Acronyms	3
1.2	Definitions	3
1.3	References	5
2	Background	6
3	Physical characteristics	7
3.2	Water runway	7
3.3	Turning basins	7
3.4	Taxi channels	7
3.5	Mooring areas	8
3.6	Shore facilities	8
4	Obstacle restriction and removal	9
4.2	Obstacle limitation surfaces	9
4.3	Displaced threshold	12
4.4	Objects and obstacles	13
4.5	Other objects	13
5	Visual aids for navigation	14
5.1	Wind direction indicator	14
5.2	Markings	14
5.3	Signs	15
5.4	Strobe lights	15
5.5	Lighting of movement area	15
6	Visual aids for denoting obstacles	16
6.2	Objects to be marked and/or lighted	16
6.3	Marking of objects	16
7	Operational considerations	17
8	Water aerodrome emergency planning	18

1 Reference material

1.1 Acronyms

The acronyms and abbreviations used in this AC are listed in the table below.

Acronym	Description
AC	advisory circular
CAR	<i>Civil Aviation Regulations 1988</i>
CASA	Civil Aviation Safety Authority
CASR	<i>Civil Aviation Safety Regulations 1998</i>
ICAO	International Civil Aviation Organisation
MOS	Manual of Standards
MTOW	maximum take-off weight
OLS	obstacle limitation surface

1.2 Definitions

Terms that have specific meaning within this AC are defined in the table below.

Term	Definition
Aerodrome	A defined area on land or water (including any buildings, installations and equipment) intended to be used either wholly or in part for the arrival, departure and movement of aircraft.
Aeroplane	A power-driven heavier than air aircraft deriving its lift in flight chiefly from aerodynamic reactions on surfaces which remain fixed under given conditions of flight.
Fixed platform	A platform extending from the shore, on water and supported by pillars to hold it in position, intended to align alongside seaplanes for the purposes of embarkation and disembarkation of passengers, loading and unloading of cargo, or refuelling or parking of seaplanes.
Floating platform	A platform placed on open water intended for the purpose of embarkation and disembarkation of passengers, loading and unloading of cargo by seaplane.
Gangway	A movable walkway where people board and disembark such as platforms, and piers.
Low water level	The average low level during that month of the year when levels are lowest or, in the case of tidal waters, the average level of low water springs or lower low waters, depending on the type of tide.
Mooring	A fixed permanent installation on the water surface used to secure seaplanes. The seaplane may be moored to a floating buoy, a pier, platforms, etc.
Mooring buoy	A buoy connected by chain or cable to a permanent unmovable anchor sunk

Term	Definition
	deeply into the bottom of a body of water.
Movement area	The part of an aerodrome to be used for take-off, landing and taxiing of seaplanes, consisting of the manoeuvring area and platforms.
Protected area	An area which is protected from large waves. The structure providing protection can be natural or constructed.
Seaplane	An aeroplane on floats (amphibious or non-amphibious) or a flying boat (water-only or amphibious).
Taxi channel	A defined path on a water aerodrome, intended for the use of taxiing seaplanes.
Turning basin	A water area used for the water taxi manoeuvring of seaplanes along shoreline facilities and at the ends of a narrow water runway.
Waterways	A river, canal or other waterbody serving as a route or way of travel or transport.
Water aerodrome	A defined area, primarily on water, intended to be used either wholly or in part for the arrival, departure and movement of seaplanes, and any building and equipment on ground or water.
Water aerodrome operator	Any organization/ or person in charge of a water aerodrome including employee, agent or other authorized representative.
Water current	The rate of flow of the water.
Water runway (channel)	A defined rectangular area on a water aerodrome, intended for the landing and take-off of seaplanes along its length.

1.3 References

Regulations

Regulations are available on the Federal Register of Legislation website <https://www.legislation.gov.au/>

Document	Title
Part 139 of CASR	Aerodromes
Part 139 Manual of Standards	Part 139 (Aerodromes) Manual of Standards
ICAO Annex 14 Aerodromes Vol 1	Aerodrome Design and Operations
CAAP 92-1	Guidelines for Aeroplane Landing Areas

Advisory material

CASA's advisory circulars are available at <http://www.casa.gov.au/AC>

CASA's Civil Aviation Advisory Publications are available at <http://www.casa.gov.au/CAAP>

Document	Title
	ICAO Asia Pacific Guidance on Requirements for the Design and Operations of Water Aerodromes for Seaplane Operations

2 Background

- 2.1.1 This advisory circular (AC) outlines the recommended specifications for the physical characteristics, obstacle limitation surfaces (OLS), visual aids, services and operating procedures to be provided at a water aerodrome.
- 2.1.2 ICAO Annex 14 does not differentiate between land and water as a surface from which aircraft can operate and states that an aerodrome can be an area of land or water. However, operations by aeroplanes on water differ significantly from those conducted on land. The specifications outlined in this AC focus on those facilities, services and equipment where water aerodromes differ from land aerodromes in terms of their design and operations.
- 2.1.3 ICAO recommends that States certify water aerodromes open to public use through an appropriate regulatory framework. CASA does not require certification of water aerodromes open to public use; therefore, CASA has notified a difference with ICAO.
- 2.1.4 When on the water, seaplanes will be subject to maritime regulations or statutes. It is recommended that water aerodrome operators and developers consult with maritime authorities to ensure applicable requirements are identified and complied with.
- 2.1.5 Caution is required within proximity of a seaplane landing and take-off area. Appropriate warning signage indicating the presence of seaplane activity should be considered.

3 Physical characteristics

3.1.1 The physical characteristics described in this section are to guide water aerodrome operators in providing a safe facility for seaplane operators.

3.2 Water runway

3.2.1 Length of water runways

3.2.1.1 In terms of required operating parameters, the length of a water runway should be adequate to meet the operational requirements of the critical seaplane for which the runway is intended. The runway should be not less than the longest length determined by applying the corrections for local conditions to the operations and performance characteristics of the relevant seaplanes.

3.2.2 Width of water runways

3.2.2.1 Wherever practicable the width of the water runway should be no less than 60 m.

3.2.3 Water depth

3.2.3.1 The depth of the water measured at low water level in the water runway should not be less than 1.8 m or not less than 0.3 m below the hull or floats when the seaplane is stationary and loaded to maximum take-off weight (MTOW).

3.2.4 Water runway strip

3.2.4.1 Wherever practicable, a protective buffer from obstacles should extend on each side from the edge of the water runway to a distance of not less than 30 m and on each end of the water runway to a distance of 60 m.

3.3 Turning basins

3.3.1 Whenever necessary, turning basins should be provided at the end of the water runway.

3.3.2 When turning basins are provided, they should have a diameter measured at low water level of at least twice the minimum width of the water runway. The depth of turning basins measured at low water level should be at least that of the water runway, and horizontal obstruction clearance should be maintained between the edge of the turning basin and the nearest obstacle of no less than 15 m.

3.4 Taxi channels

3.4.1 Wherever practicable, taxi channels should be provided to permit the safe and expeditious handling of aerodrome traffic. Where provided, the taxi channels should have a width of not less than 45 m.

3.4.2 Wingtip to wingtip clearance for passing seaplanes (dual directional taxi channels) should be not less than 15 m.

- 3.4.3 The depth of the water measured at low water level in the taxi channel should not be less than 1.8 m or less than 0.3 m below the hull or floats when the seaplane is stationary and loaded to MTOW.

3.5 Mooring areas

- 3.5.1 Mooring areas should be provided, whenever necessary, for the mooring of seaplanes and to permit the embarkation and disembarkation of passengers, loading and unloading of cargo without interfering with aerodrome traffic.
- 3.5.2 The size of the mooring areas should be adequate to permit expeditious handling of the peak hour traffic and the depth of water at the mooring area measured at low water level should be at least that of the corresponding taxi channel. Depending on water level the mooring area should be designed in such a manner as to provide a minimum clearance of 15 m between any part of the seaplane and any object which it could come into contact.

3.6 Shore facilities

- 3.6.1 A platform (fixed or floating), ramp or beach should be provided to permit the embarking and disembarking of passengers and crew, loading and unloading of cargo and refuelling.
- 3.6.2 Platforms should:
- be in a condition that permits constant use without causing injury to persons or damage to aircraft
 - be attached or anchored in a manner that prevents it from shifting position or becoming detached
 - have access from the shore that provides for the safe movement of crew and passengers
 - have at least two bull rails or provision for appropriate number of tie-down cleats at each seaplane parking position to secure the seaplane.
- 3.6.3 When a seaplane is normally secured in a position where any seaplane component overhangs the platform and constitutes a hazard to the movement of crew and passengers, the hazard should be clearly indicated by cones and/or hashed red and white markings, and in a manner easily identifiable to crew and passengers.
- 3.6.4 Where a ramp or beach is provided it should:
- be built 1.5 times the width of floats or landing gear of the largest seaplane intended to use the facility
 - located in such a manner as to provide a minimum clearance of 1.8 m between a seaplane wing and any object which it could come into contact
 - be constructed with a slope not steeper than 1:8.

4 Obstacle restriction and removal

4.1.1 This chapter establishes a series of Obstacle Limitation Surfaces (OLS) that define the limits to which objects may project into the airspace in order to minimize the dangers presented by obstacles, either during take-off or approach of seaplanes at water aerodromes.

4.2 Obstacle limitation surfaces

4.2.1 The OLS in Figure 1 should be established for non-instrument water aerodromes with a take-off climb/approach surface, transitional surface, and an inner horizontal surface.

Figure 1 - Water Aerodrome OLS

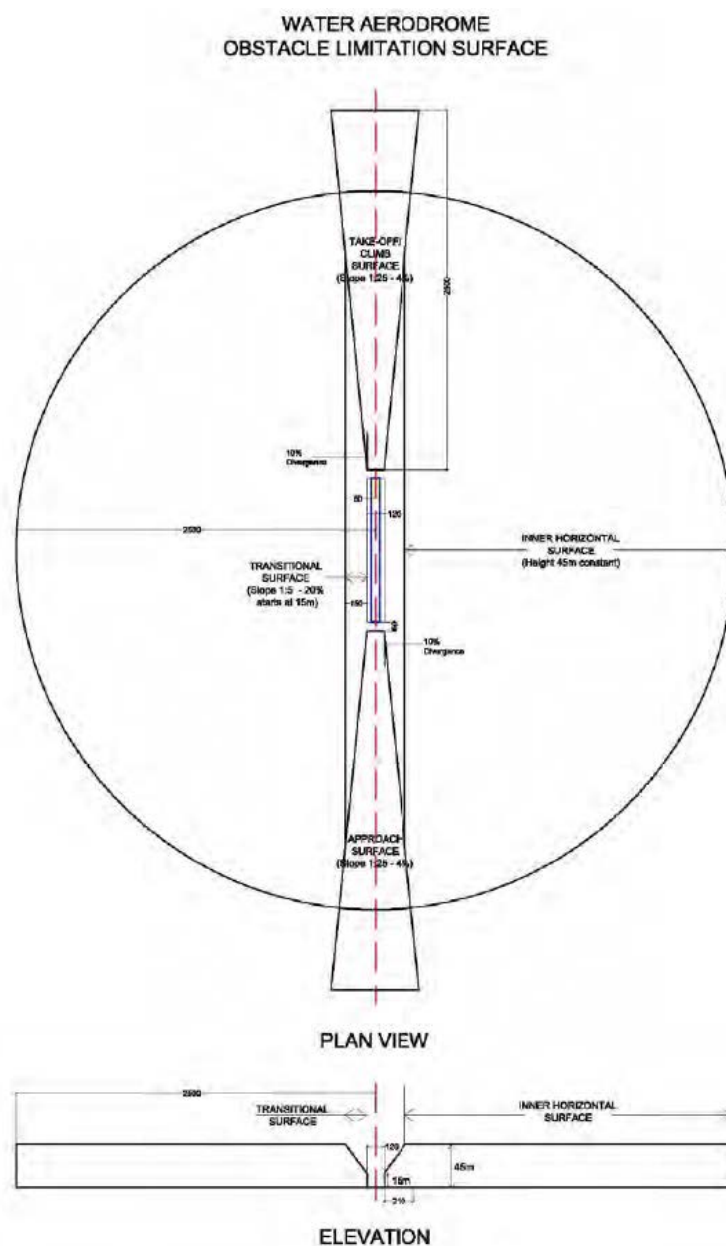

4.2.2 Reference elevation datum

4.2.3 All surfaces should be determined using the aerodrome reference elevation datum. The datum should be determined by the elevation point of the lowest recorded water level.

4.2.4 Take-off climb/approach surface

4.2.4.1 The take-off climb/approach surface should be either straight or curved and be established at the end/beginning of the water runway strip.

4.2.4.2 The characteristics of the take-off climb /approach surface should be the:

- Width of the inner edge should not be less than that of the associated water runway strip
- Inner edge should start at 60 m from threshold of water runway
- Elevation of the inner edge should be the reference elevation datum
- Length of the take-off climb /approach surface should not be less than 2500 m from the inner edge
- Slope of the take-off climb/approach surface should be a minimum of 4 % (1:25)
- Centre line of the take-off climb/approach surface should define the approach path and be one of the following:
 - o a straight line
 - o an arc of constant radius
 - o a combination of a straight line and an arc of constant radius.

4.2.5 Straight-in take-off climb/approach surface

4.2.5.1 Where the slope is designed for a straight-in approach the divergence of the take-off climb/approach surface should be set at 10% starting from the inner edge. The surface can be constructed using the parameters outlined in Table 1.

Table 1 Straight-in Take-off climb/Approach surface parameters

Approach type – Non-instrument	
Take-off climb/approach surface	
Width of inner edge	Width of water runway strip - (120 m minimum)
Location of inner edge	60 m from the threshold
Divergence take-off climb/approach surface	10 %
Length (minimum)	2500 m
Slope of take-off climb/approach surface (maximum)	4% (1:25)
Transitional Surface:	
Slope (maximum)	Vertical to 15 m then 1:5 (20 %)
Inner Horizontal Surface:	
Height	45 m
Radius	2,500 m

4.2.6 Curved take-off climb/approach surfaces

- 4.2.6.1 Where established, a curved take-off climb/approach surface should not contain more than one curved portion.
- 4.2.6.2 A curved portion of a take-off climb/approach surface should not allow a change of direction greater than 90 degrees.
- 4.2.6.3 Where a curved portion of take-off climb/approach surface is provided:
- the straight portion originating at the inner edge should not be less than 1300 m
 - the radius of arc defining the centre line of the take-off climb/approach surface should not in any portion of the take-off climb/approach surface be less than 736 m in accordance with Figure 2.
- 4.2.6.4 A take-off climb/approach surface incorporating a curved portion should be established only where guidance, such as, geographical points or other visual references are available.
- 4.2.6.5 A curved approach is normally established at a non-instrument water runway where it is necessary to avoid obstacles, terrain, noise sensitive areas, or to utilise the airspace above public lands (e.g. freeways, rivers, golf courses).

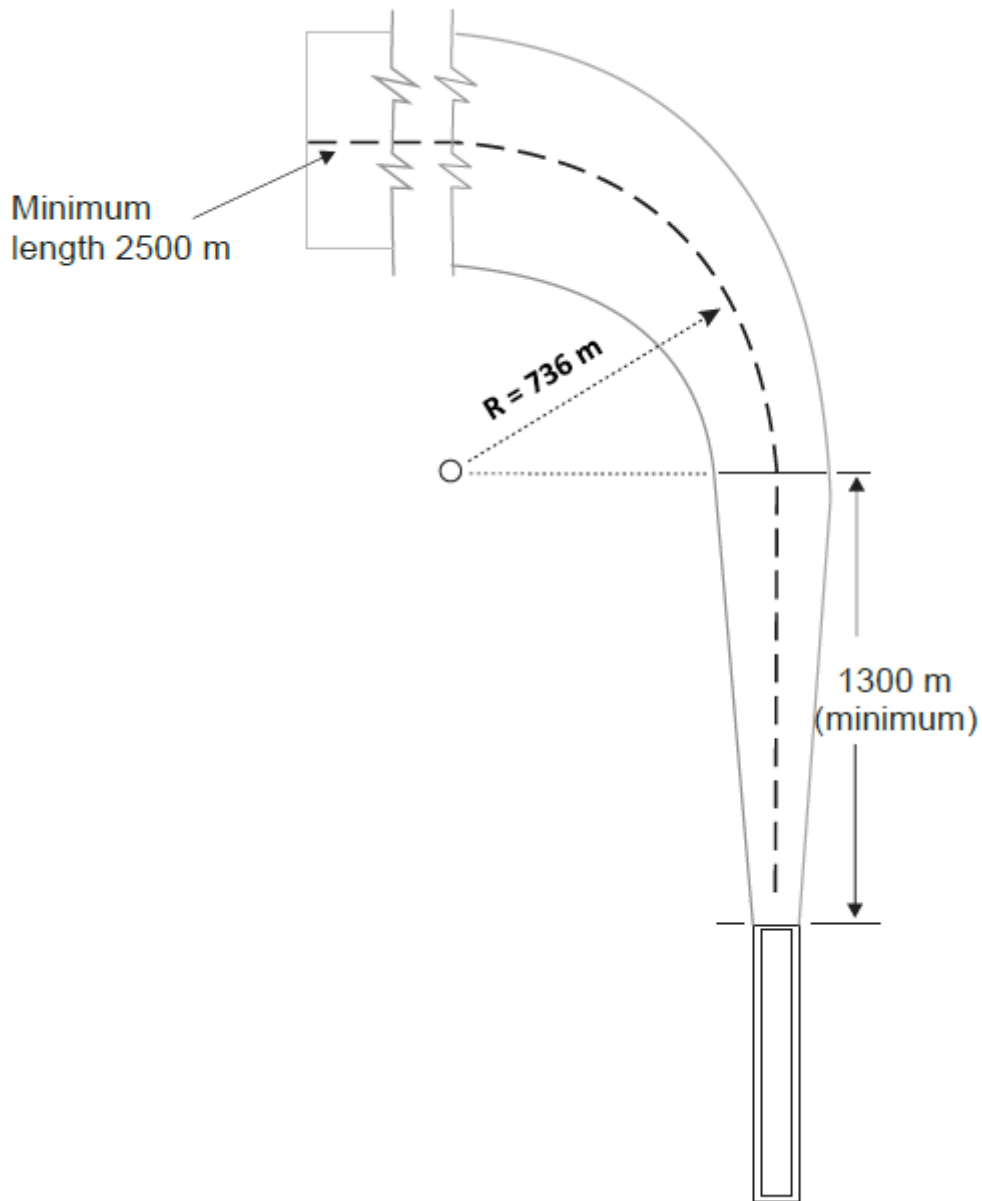

Figure 2 - Curved Take-off climb/Approach surface diagram

4.3 Displaced threshold

- 4.3.1 Where the integrity of the approach surface cannot be maintained due to fixed or mobile obstacles, a landing threshold should be displaced from the normal threshold.
- 4.3.2 This displacement should be established so that the new approach surface, starting at the displacement, will clear all obstacles.

4.3.3 Where a threshold has been displaced, the inner edge of approach surface should be located at 60 m from the point of displacement.

4.4 Objects and obstacles

4.4.1 No fixed object should be permitted on a water runway or on a water runway strip.

4.4.2 Fixed objects or structures that are located within the water aerodrome boundary should not penetrate OLS unless those structures are:

- for air navigation purposes
- are essential to the safety of aircraft operation
- are marked in accordance with Part 139 MOS, Chapter 8, Division 10 and are frangible.

4.4.3 A mobile object should not penetrate take-off climb/approach surfaces, unless procedures are in place to ensure the object is removed during approach and departure operations.

4.5 Other objects

4.5.1 Where an aeronautical study (safety risk assessment) indicates that an object is hazardous to seaplane located on the movement area or in the air in the immediate vicinity of the water aerodrome, it should be removed or marked and/or lighted in accordance with the Part 139 MOS Chapter 8 Division 10.

5 Visual aids for navigation

5.1 Wind direction indicator

- 5.1.1 Unless the direction of the wind can be obtained by the pilot, at least one wind direction indicator should be installed.
- 5.1.2 Where a wind direction indicator is installed it should be:
- of an international orange; or
 - orange and white or red and white colour; and
 - in the form of a truncated cone.
- 5.1.3 The wind direction indicator(s) should be visible at a height of 300 m above the water runway and visible from any portion of the manoeuvring area.

5.2 Markings

5.2.1 Dock identification marking

- 5.2.1.1 Dock identification markings should consist of a triangle and painted bull rails as specified below.
- 5.2.1.2 Both markings should be affixed to the upper surface of the dock so as to be visible from 300 m above the water runway.

5.2.2 Bull rails

- 5.2.2.1 Where bull rails are installed, they should be painted in alternated bands of international orange and white stripes.

5.2.3 Gangways

- 5.2.3.1 Gangways should have signage provided indicating seaplane access only.

5.2.4 Marker buoys

- 5.2.4.1 Marker buoys should be visible to aircraft manoeuvring on the surface of water and aircraft 300 m above the water runway.

5.2.5 Water runway markers

- 5.2.5.1 Except at water aerodromes and where there is no conflict with marine traffic or marine regulations, both ends of the take-off and landing area should be marked with floating markers. The markers should be visible to airborne pilots from a distance greater than 2 NM and each marker should be of international orange in colour or alternating international orange and white.
- 5.2.5.2 Where it is impracticable to mark the water runway as specified above, guidance such as geographical points and/or other visual references should be provided to designate

the take-off and landing area and these visual references should be identified and published.

5.2.6 Displaced threshold markers

5.2.6.1 Where a threshold is displaced permanently or temporarily, the threshold displacement should be marked with floating markers. The markers should be visible to airborne pilots from a distance of at least 2 NM and each marker should be international orange or the markers should be alternating international orange and white.

5.2.7 Hazardous area markers

5.2.7.1 Where shoals or other hazards could endanger a seaplane, marker buoys should be installed to clearly indicate the hazardous area.

5.2.7.2 Marker buoys for delineating hazardous area should be distinctly marked from water runway markers in colour and shapes.

5.3 Signs

5.3.1 Prohibition signs

5.3.1.1 A sign should be provided and displayed on the dock restricting the dock to seaplane operations only.

5.3.1.2 A sign should be displayed on the dock restricting passengers from the docking area until all seaplanes and propellers have come to a complete stop.

5.4 Strobe lights

5.4.1 Strobe lights should be installed to delineate water aerodrome facilities wherever necessary. Where installed, the strobe lights should be white, quick flashing, and located in an area that is easily and constantly seen by both marine and air traffic.

5.5 Lighting of movement area

5.5.1 Wherever necessary, water aerodrome identification and manoeuvring area lighting should be provided for reduced visibility conditions.

5.5.2 A lighted water aerodrome can be identified by a beacon alternating white and yellow flashes at the rate of 12 to 30 flashes per minute.

5.5.3 In water traffic congested areas, a radio activated strobe beacon may be used to alert mariners and other airman that a seaplane will be arriving or departing within a short time.

5.5.4 Wherever necessary, floodlights or spotlights should be installed on the shore to illuminate aprons, floats, ramps, and piers. Care must be taken in locating and aiming floodlights to preclude affecting the vision of pilots landing or taking off or creating distracting reflections.

6 Visual aids for denoting obstacles

6.1.1 The visual aids described in this section are to guide water aerodrome operators in providing a safe facility for seaplane operators.

6.2 Objects to be marked and/or lighted

6.2.1 Fixed objects

6.2.1.1 Objects that are conspicuous by their shape, size or colour need not be marked.

6.2.1.2 Except as covered under the Marine Safety National Law Act, objects should be marked in accordance with section 5.2 of this AC.

6.3 Marking of objects

6.3.1.1 Except as specified in section 5.1.2 of this AC all fixed objects should be marked in a conspicuous colour.

6.3.1.2 Where it is not possible to colour the objects, markers or flags should be displayed on or above the objects.

6.3.2 Use of colours

6.3.2.1 The colour and form of marking displayed on objects should be in accordance with Part 139 MOS Chapter 8 Division 10.

6.3.3 Use of markers

6.3.3.1 Markers displayed on or adjacent to objects should be located in conspicuous positions so as to retain the general definition of the object. They should be recognizable in clear weather from a distance of 1000 m for an object to be viewed from the air or 300 m for an object to be viewed from the ground (in all directions in which a seaplane is likely to approach the object).

6.3.3.2 The shape of the markers should be distinctive to the extent necessary to ensure that they are not mistaken for markers employed to convey other information, such that the hazard presented by the object they mark is not increased.

6.3.3.3 The colour selected should contrast with the background against which it will be seen.

7 Operational considerations

7.1.1 Wildlife strike hazard

7.1.2 The presence of wildlife (birds) on and in the water aerodrome vicinity may pose a serious threat to seaplane operational safety. Action should be taken to decrease the risk to seaplane operations by adopting measures to minimize the likelihood of collisions between wildlife and seaplane.

7.1.3 The objectives of wildlife hazard management outlined in Part 139 MOS Chapter 17 can be applied to water aerodromes.

7.1.4 Aeronautical Information Publication

7.1.5 Water aerodrome information should be relayed to Airservices' Aeronautical Information Service for publication in the Aeronautical Information Publication (AIP)

7.1.6 Safety management system

7.1.7 A safety management system (SMS) should be considered for a water aerodrome, given the complexity of the operating environment. However, if the water aerodrome is small and facilitates only simple operations, a risk management plan is sufficient.

7.1.8 Operational procedures

7.1.9 During operational hours, inspections of the movement areas to remove FOD or other hazards should be undertaken.

7.1.10 A maintenance program is recommended as a means to ensure that all markers, signs, lighting and other infrastructure that supports the operation of seaplanes remain fit for purpose and suitably visible.

7.1.11 Environment

7.1.12 In seeking approval for establishment of a water aerodrome, the relevant land use authority may require an environmental analysis. This evaluation should include an analysis of the proposals impact on:

- water quality
- wildlife
- existing and proposed land use
- noise
- historical/archaeological factors.

7.1.13 Where aviation fuel is provided at a public water aerodrome base, care must be taken to ensure that the storage and delivery systems are safe and that precautions are taken to minimize the possibility of spills and the resulting adverse environmental effects of a fuel spillage. The design of fuelling facilities and storage areas should comply with local regulations and accepted measures for pollution prevention. Most states have their own environmental laws or regulations as well, all of which need to be considered and followed prior to establishing a water aerodrome.

8 Water aerodrome emergency planning

- 8.1.1 The objectives of emergency planning outlined in Part 139 MOS Chapter 24 can be equally applied to water aerodromes.
- 8.1.2 Minimum expectations when planning and preparing an emergency response should necessitate engagement with local agencies that are likely to assist. Established procedures should be developed, with the procedures represented in the local emergency response plan.
- 8.1.3 When establishing emergency response arrangements, the hazards associated with seaplane operations, including passenger evacuation should be considered. For example:
- deep water
 - the onset of hypothermia and its associated effects, during and following prolonged immersion in cold water
 - the immediate toxicity and respiratory effects on survivors in the water following the ingestion of floating fuel and oils and their associated vapours
 - fire suppressant foams, powders and gases.
- 8.1.4 The emergency response arrangements should contain provisions for water rescue, fire response and recovery of disabled aircraft from the movement area.
- 8.1.5 Consideration should be given to:
- number of persons that the largest aircraft can carry
 - local hazards (water temperatures)
 - availability of rescue boats (shallow water/surface considerations)
 - flotation equipment, rafts
 - thermal blankets
 - adequate two-way radio equipment should be provided in all rescue boats in order to maintain communication
 - flood lighting should be available for night operations
 - a command post and casualty areas should be established at a safe location on adjacent land.
- 8.1.6 The emergency response arrangements should contain procedures for periodic testing to ensure their adequacy and to improve its effectiveness.
- 8.1.7 Local responders should be familiar with the operating environment and the established emergency response arrangements.